TREES & DEVELOPMENT GUIDELINES FOR COVENTRY

Supplementary Planning Document
December 2018



DRAFT

Abbreviations 4

Introduction 4

 Purpose 5

 Aims & Objectives 5

Context 7

 Legislation, Guidance & Policy 8

 The Importance of Trees 11

 History of Trees in Coventry 14

Planning for Trees Pre-development 16

 Land Surveys 16

 Tree Surveys 16

 Tree Constraints Plan 19

 Arboricultural Method Statements 19

 Capital Asset Value for Amenity Trees 20

 Design Criteria 21

 Applying for Planning Permission 22

Planning for Trees In-development 23

 Implementation 24

 Avoiding Damage to Existing Trees 24

 Direct & Indirect Damage 25

 Tree Works 26

 Tree Protection Measures 27

 Root Protection 29

 Avoiding Other Damage 31

 Principles of Tree Planting 32

 Avoiding Future Conflict 33

 Planting New Trees 34

 Site Layout 35

 Site Access 37

Monitoring & Review 38

*“The tree which moves some to tears of joy is in the eyes of others only a green thing
that stands in the way”*

Letter to Revd. Dr. Trusler; William Blake, 1799

*“There is little in the architecture of a city that is more beautifully designed than a
tree.”*

Jaime Lerner, Architect and Urban Planner –
Mayor of Curitiba (1971-1974, 1979-1983, 1989-1992)

ABBREVIATIONS

AIA – Arboricultural Impact Assessment
AMS – Arboricultural Method Statement
BS – British Standard
CAVAT – Capital Assessment for Amenity Trees
CEZ – Construction Exclusion Zone
LPA – Local Planning Authority
LTOA - London Tree Officer's Association
NATO – National Association of Tree Officers
NHBC – National House Building Council
NPPF – National Planning Policy Framework
PPG – Planning Practice Guidance
RPA – Root Protection Area
SMS - Site Monitoring Sheet
SPD – Supplementary Planning Document
TCP – Tree Constraints Plan
TPM – Tree Protection Measures
TPO – Tree Preservation Order
TPP – Tree Protection Plan

INTRODUCTION

PURPOSE

- 1.1. Trees are a significant and highly visual component in the landscape, and as public awareness of environmental issues becomes more influential, there is an increasing need to focus attention on trees and their role in providing not only a pleasant environment, but their value to biodiversity and mitigating the adverse impacts of climate change.
- 1.2. This draft Supplementary Planning Document (SPD) allows Coventry City Council to respond to these sentiments and build upon the policies included in the Coventry Local Plan 2016 (hereby referred to as the Local Plan) when and where it relates to trees in Coventry, and the preservation and protection of trees during new development, and on existing sites. More generally, it describes and explains how the Council will interpret and apply the relevant sections of Planning Practice Guidance (PPG), and the National Planning Policy Framework (NPPF).
- 1.3. Furthermore, it will help to inform developers, land-owners, agents, architects, planning consultants, landscape architects, arboriculturists', contractors and other interested parties of the standards that the Council expects from new development proposals with regard to existing trees. It seeks to ensure that important trees are afforded due consideration in the planning process, so that they can be effectively integrated into new developments.
- 1.4. This document provides a comprehensive guide to the planning system, and the preservation and protection of trees during development in Coventry. For this reason, the intention of this document is to lead to an improved approach to the retention and planting of trees; thus making an important contribution to sustainable development in the city.
- 1.5. The structure of this document has been set out to follow the logical sequences by which development matters are generally processed; i.e. site surveys, development planning and organisation, obtaining planning permission and subsequent implementation; as identified in **BS 5837:2012 - Trees in Relation to Design, Demolition and Construction** ¹.

AIMS & OBJECTIVES

- 1.6. The Council is committed to ensuring that development proposals provide positive environmental benefits; including promoting the benefits of trees throughout the city, and thus encouraging sustainable management of the city's trees and enhancing the quality of their tree cover. This will be achieved in the

¹ Permission to reproduce extracts from British Standards is granted by BSI Standards Limited (BSI). No other use of this material is permitted. British Standards can be obtained in PDF or hard copy formats from the BSI online shop: www.bsigroup.com/Shop

first instance through negotiation, or if necessary by using council planning powers.

- 1.7. The necessity for an organised, methodical, coordinated and standard approach to ensure the effective integration of trees into new development is formalised within **BS 5837:2012**. It is considered as the national standard for the approach to tree protection.
- 1.8. It is intended that this document will help to facilitate a quality, systematic approach to the retention and planting of trees, by explaining the approach to tree and development issues that will be required by the Council to comply with its own planning policies as established and adopted in the Local Plan.
- 1.9. For these reasons, this document is underpinned by the following aims:
 - To provide details around the tree related Local Plan policies (most notably Policies GE3 and GE4).
 - Aid the process of determining planning applications where trees are concerned.
 - Assist in the arboricultural management practices of parks, garden and city trees.
 - Provide advice about trees in Coventry.
 - Guide development to meet and exceed best-practice examples and proven standards.
- 1.10. The following guidelines set out the procedures and design criteria necessary to ensure the successful integration of existing trees, and the planting of new trees, into development proposals. Compliance with these will ensure that sufficient information is submitted to enable the Council to assess the full long-term effect and impact of any new development and avoid unnecessary delays in the decision-making process.



Bannerbrook Park

Existing mature trees successfully integrated into new residential development by careful consideration and protection throughout the survey, design and construction stages.



LEGISLATION, GUIDANCE & POLICY

- 1.1. The Council will take account of adopted local plan policies, relevant supplementary planning statements and documents, and the most up-to-date legislation, government advice and recommendations (as issued through the NPPF and NPPG).
- 1.2. This document is informed by, and must conform to, those relevant pieces of legislation, guidance and policy issued by government. They are set out below:
- 1.3. The **Town and Country Planning Act 1990 (Part VIII, Section 197)**² recognises the importance of trees and charges local planning authorities with a specific 'duty' in relation to their preservation and planting. Subsequent sections (up to and including Section 214) provide the powers and details surrounding Tree Preservation Orders (TPO), and Trees in Conservation Areas.
- 1.4. At present – in terms of statutory tree protection - there are over 450 TPO's, covering approximately 4500 trees, whilst there are also 16 Conservation Areas in Coventry covering many more. In the interests of transparency, the Council's evaluation method for TPO assessment, and its making and serving procedure are included in Appendix 1 and 2.
- 1.5. The **Hedgerow Regulations 1997 (SI 1997/1160)**³, implemented under **Section 97 of The Environment Act 1995**, require Local Planning Authorities, in determining planning applications, to consider the effects of proposed developments on 'important' hedgerows. Specifically it was created to protect rural hedgerows which are at least 30 years old, or play a significant role in archaeology/history of an area.
- 1.6. The **Natural Environment and Communities Act 2006**⁴ provides that any public body or statutory undertaking in England and Wales must have regard to conserving, enhancing, restoring and/or protecting biological diversity in the execution of its functions.
- 1.7. **National Planning Policy Framework (NPPF) and Planning Practice Guidance (PPG)** set out the government requirements for the planning system, this includes ancient woodlands and veteran trees.

² Part VIII of the Act can be found using the following hyperlink:
<https://www.legislation.gov.uk/ukpga/1990/8/part/VIII>

³ The entire regulations can be found using the following hyperlink:
<http://www.legislation.gov.uk/uksi/1997/1160/contents/made>

⁴ The entire Act can be found using the following hyperlink:
<https://www.legislation.gov.uk/ukpga/2006/16/contents>

- 1.8. The NPPF⁵ was published in July 2018 and sets out the UK Government's planning policies for England and how these are expected to be applied. Of particular relevance to this document are paragraphs 170, 171, 175, 180 and 181. Within these sections, it is made explicitly clear that the planning system and the decision-making process in relation to planning applications must protect and minimise the impact upon ecological networks on a broad level whilst also enhancing the local natural environment.
- 1.9. Trees are given specific protection through paragraph 170(b) and 175(c). On a general level, ancient woodland is considered to be an "irreplaceable habitat", and thus emphasising the significant importance attached to these areas. Furthermore, aged and veteran trees and ancient woodland are now specifically protected under the notion of; "presumption in favour of sustainable development", therefore, development that involves the loss of aged and/or veteran trees or ancient woodland should be refused. In addition, all benefits of trees and woodland (including economic) should be protected and enhanced, even on the scale of simply recognising the beauty and character that natural capital provides.
- 1.10. The important role that trees play in the maintenance and improvement of air quality alongside noise and visual damping/buffering qualifies them for protection through paragraphs 180 and 181 amongst others.
- 1.11. A suite of information underpinning the NPPF is available in the form of PPG⁶. The PPG is revised continuously and provides further details to the NPPF. It is regularly updated in line with changes to government policy and legislation. The most significant chapters concerning trees are; '*Natural environment*', '*Tree Preservation Orders and trees in conservation areas*' and '*Air quality*'. Within them there are strong references to the safeguarding of ancient woodlands and aged and veteran trees. For this reason the Council will consult with the Forestry Commission and Natural England to seek their advice and assistance when appropriate.
- 1.12. Ancient trees and Woodland are living remnants from the past historic landscape, which typically have existed since the 1600's. Ancient woodlands and veteran trees are irreplaceable. Veteran and Ancient trees display wildlife features for forage and shelter which including exposed sapwood, cavities, deadwood, sap runs, heartwood decay and stag-heading back of crown etc. The National Practice Guidance issued by the Forestry Commission and Natural England 'Ancient woodland and veteran trees: protecting them from development' recommends that they require a Root Protection Area (RPA)

⁵ The framework in its entirety can be found using the following hyperlink:
<https://www.gov.uk/government/publications/national-planning-policy-framework--2>

⁶ The guidance in their entirety can be found using the following hyperlink:
<https://www.gov.uk/government/collections/planning-practice-guidance>

radius equivalent to 15 times their trunk diameter rather than the x12 trunk diameter given by BS 5837:2012 or 5m from the edge of its canopy, whichever is greater.

1.13. The Planner's Manual for Ancient Woodland and Veteran Trees (October 2017) recommends that a minimum buffer of 50 meters should be maintained between a development and the ancient woodland, including the construction phase. Although there is no 'one size fits all' approach to buffer design, each proposal should be designed to fulfil the specific requirements of its location and the type of proposed development. As a precautionary principle, a minimum 50m buffer should be maintained between a development and the ancient woodland, including through the construction phase, unless the applicant can demonstrate very clearly how a smaller buffer would suffice. The preferred approach is to create new habitat, including native woodland, around existing ancient woodland. This will help reverse the historic fragmentation of this important habitat. The consequent increase in ecological connectivity between areas of ancient woodland will create the resilient landscapes recommended in 'Making Space for Nature' (DEFRA, 2010).

1.14.

1.15. **The Coventry Local Plan 2016**⁷ contains the required tree and landscape related policies which include; **GE1, GE2, GE3** and **GE4**. Of particular relevance to this SPD are policies GE3 and GE4 which set out what is expected of applicants with regards to the protection of trees when determining planning proposals. As per national requirements, ancient woodland will be protected in the first instance, and where possible enhanced as a component of green infrastructure. All existing trees (especially trees protected under a TPO), individual or groups of ancient trees, ancient and newly-planted woodland and ancient hedgerows, are expected to be safeguarded against loss and/or damage.

1.16. Just as importantly are the heritage policies of the local plan; **HE1, HE2** and **HE3**. Of particular worth to tree protection is policy HE2 which sets out how the Council will sustain the historic character and local distinctiveness of areas recognised to contain special historic, landscape and/or townscape significance amongst other things. It is recognised that trees play a fundamental part of these significances and therefore are afforded a high level of protection as a

⁷ The Local Plan in its entirety can be found using the following hyperlink:
http://www.coventry.gov.uk/downloads/file/25899/final_local_plan_december_2017.

result. Indeed, trees located within Conservation Areas are automatically protected to the equivalent level of a TPO.

- 1.17. Furthermore, the Local Plan makes consideration to planning for climate change through policy **EM1**. It has been established that preparation for/minimisation of climate change impacts can partly be met through the appropriate application of green infrastructure. This includes the retention and planting of trees as tools for; urban cooling, shading, flood risk management and ecological sustainability.
- 1.18. Should exceptional circumstances be proven and it is considered that the benefits of conserving any trees is outweighed by the benefits of development, then compensatory provisions will be mandatory. This could be in the form of replacement trees as close as possible to the proposed development, or alternatively the Council will request a financial contribution from the developer; a sum equivalent to the value of the removed tree(s). This valuation should be calculated using an appropriate assessment agreed with the Council. The Council recommends employing the **CAVAT** approach. Please refer to paragraph 3.16-3.25 of this SPD for details on this methodology.

THE IMPORTANCE OF TREES

- 1.19. Trees are of fundamental importance to the landscape and are widely appreciated for enhancing the urban and rural environment. They make a positive contribution to the scenic character and diversity of the landscape and built environment. Furthermore, their role in biodiversity is vital as their physical structure is crucial to vast amounts of life.
- 1.20. Equally as importantly is their role in sustaining and enhancing biodiversity as their physical structure is crucial to vast amounts of life, primarily by providing shelter and nutrients.

DRAFT

Why trees are good for us

Trees are an important part of our lives and have many hidden benefits that are not always obvious. For example, trees reduce skin cancers and help reduce flash flooding.

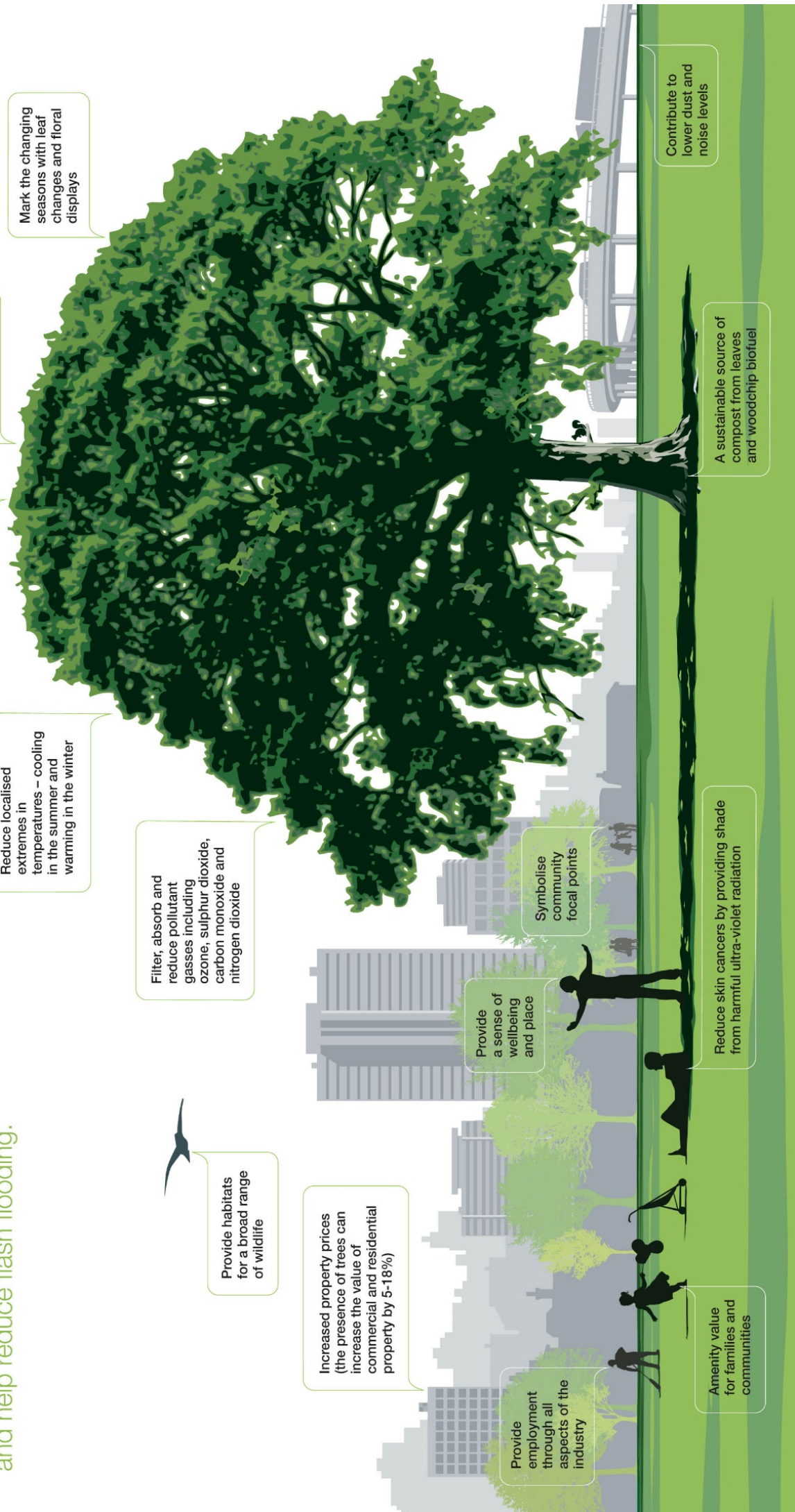

- Produce oxygen and absorb carbon dioxide
- Release scents and aromas that create a positive emotional response
- Mark the changing seasons with leaf changes and floral displays
- Reduce localised extremes in temperatures – cooling in the summer and warming in the winter
- Filter, absorb and reduce pollutant gasses including ozone, sulphur dioxide, carbon monoxide and nitrogen dioxide
- Provide habitats for a broad range of wildlife
- Increased property prices (the presence of trees can increase the value of commercial and residential property by 5-18%)
- Provide employment through all aspects of the industry
- Provide a sense of wellbeing and place
- Symbolise community focal points
- Reduce skin cancers by providing shade from harmful ultra-violet radiation
- A sustainable source of compost from leaves and woodchip biofuel
- Contribute to lower dust and noise levels
- Amenity value for families and communities

- 1.21. In addition, trees play an essential role in mitigating the adverse impacts of climate change by absorbing carbon dioxide and other pollutant gasses and producing oxygen. By reducing localised extremes in temperatures, trees can also lower energy consumption and costs for heating in winter, and air conditioning in summer.
- 1.22. In a development context, the retention of trees provides an immediate sense of maturity which benefits sites and their surroundings; helping to raise the overall quality of schemes and support enhanced property values. However, where trees are damaged and subsequently decline and die, or where inappropriate design leads to conflict, trees can become a source of complaint and ultimately, any positive benefits are lost.

HISTORY OF TREES IN COVENTRY

- 1.23. The area where Coventry now stands was once covered by the Arden Forest. Large areas of the Forest were cleared for agriculture during the Bronze Age and subsequent Roman occupation. The Forest may have grown back to some extent after the Romans left, but it is also possible that the Roman and medieval landscape character were broadly similar anyway i.e. a mosaic of enclosed and unenclosed pasture, inter-mixed with woodland.
- 1.24. This ancient landscape now exists mainly only in the north west of the city in Coventry's Ancient Arden Historic Landscape Area. However, remnants of the hedges and hedgerow Oaks still remain scattered throughout the urban area. Medieval Oak woodlands have survived quite well on the west and south-west of Coventry, and these and are also frequently associated with archaeological interest.
- 1.25. Many of the grandest trees remaining in Coventry originate from the Victorian period. They are the result of designed landscapes during a wealthy period in the city's history. Traders in the 19th Century built homes with large gardens planted with fashionable trees of the time, including mixed groups of non-native conifers such as Cedars and Redwoods. The tree which has safely remained as the oldest tree within the inner-City is the historic Mulberry tree which was originally located within a Spon Street Victorian Watchmaker's garden, now resides within the grounds of a large department store off Croft Street. Many of these large houses have since been converted into schools, nursing homes etc., yet the trees have been relatively well preserved.
- 1.26. The 'Spinney', on the south of the city, evolved from waste land and was formalised by the Victorians. It combines with a double Oak avenue, planted about 220 years ago along the Kenilworth Road, to form one of the finest assets of Coventry in arboricultural terms, providing a very attractive and grand entrance into the city from the South. This is incorporated into the Kenilworth Road Conservation Area.

1.27. Sir Joseph Paxton, who established the first major arboretum in the country at Chatsworth, also created a fine arboretum in Coventry as part of his design for the London Road Cemetery (opened in 1847). Many of the originally planted trees remain today. These include an avenue of unique high-grafted Candelabra Weeping Silver Limes, high-grafted Narrow Leaved Ash, and a selection of introduced exotic coniferous trees from around the world. The design of the cemetery carries the prestigious award of Grade 1 listed Parks and Gardens, by Historic England.

1.28. Other mature trees from the 20th Century mainly relate to municipal planting, such as the London Plane avenue along Holyhead Road, and Limes planted as street trees in areas such as the Butts. Unfortunately however, during the 1970's, along with the rest of the country, Coventry lost thousands of Elm trees through civic felling programmes. Climate change brings new threats of pests and disease to our trees including Phytophthora, Oak Processionary Moth, and Ash Dieback amongst others.



Above + right – Victorian planting at Coundon Court School.



Below – Arboretum at London Road Cemetery



Left – Cadelabra Weeping Silver Limes

PLANNING FOR TREES PRE-DEVELOPMENT

The format of the rest of this document has been set out to follow the logical sequences by which development matters are generally processed; i.e. site surveys, development planning and organisation, obtaining planning permission and subsequent implementation; as identified in **BS 5837:2012**.



- 2.2. Existing trees on development sites are particularly vulnerable to damage during the construction process. Careful planning is essential to achieve a functionally effective, sympathetic development, whilst at the same time ensuring the long-term retention of trees. The starting point to producing a successful design that achieves this, is the gathering of information, particularly from carrying out a thorough and comprehensive site survey, both topographical and arboricultural.

LAND SURVEYS

- 2.3. A **Land Survey** should show all existing features in and around the site, detailing the accurate locations of all vegetation (trees, hedges and shrub masses), structures, old buildings, watercourses, ponds, ditches, services, service runs, roads, driveways, walls and any areas of nature conservation interest.
- 2.4. A detailed levels survey should be incorporated showing existing contours or spot heights throughout the site. Levels information is very important in order to ensure that existing ground levels are maintained around retained trees.
- 2.5. Land surveys will be expected to meet the requirements of **Section 4.2** of **BS 5837:2012** and should follow the standard drawing conventions within **BS 1192:2007**.
- 2.6. For the avoidance of doubt, should the land survey not meet the requirements set out above, the application would either; not be validated, refused, or suggested to be withdrawn.

TREE SURVEYS

- 2.7. The majority of planning applications involve development proposals on sites which contain, or are in close proximity to, existing trees. In such cases, the Council will normally require the submission of a detailed **Tree Survey** produced in accordance with **Section 4.4, 4.5 and 4.6** of **BS 5837:2012**, in conjunction with the aforementioned Land Survey.
- 2.8. Tree Surveys should plot the accurate locations of all existing trees and should detail the following information, in accordance with **Section 4.4[.2.5]** of **BS 5837:2012** in plan or tabular form:

- a) **Reference Number** – for each specific individual tree.
- b) **Species** – common and scientific names.
- c) **Height (m)** – from ground to top.
- d) **Stem Diameter (mm)** – measured at 1.5m above adjacent ground level (on sloping ground to be taken on the upslope side of the tree base) or immediately above the root flare for multi-stemmed trees.
- e) **Branch Spread (m)** – taken at the four cardinal (compass) points to derive an accurate representation of the crown.
- f) **Height (m)** – of crown clearance above adjacent ground level (to inform on ground clearance, crown stem ratio and shading).
- g) **Age Class** – young, middle aged, mature, over-mature, veteran.
- h) **Physiological Condition** - good, fair, poor, dead & **Structural Condition** – collapsing, presence of any decay or physical defect; along with any **Preliminary Management Recommendations** – including further investigation of suspected defects and potential wildlife habitats.
- i) **Estimated Remaining Contribution (years)** - <10, 10-20, 20-40, >40.
- j) **Tree Quality Assessment** – (see table 1 of BS 5837:2012) to be recorded in plan on the Tree Survey drawing. This should also include sub-categories; 1 – mainly arboricultural values, 2 – mainly landscape values, 3 – mainly wildlife values.

2.9. It is important to note that Tree Surveys must be prepared by professionally qualified and experienced arboricultural consultants and should be available before any detailed design decisions are made in relation to the development proposals.

2.10. Where hedgerows or lengths of hedgerow are to be removed to facilitate developments, sufficient information should be submitted to allow the Local Planning Authority (LPA) to:

- Assess whether the proposed removals fall within the scope of the **Hedgerow Regulations 1997**.
- Assess whether the hedgerows to be removed are 'important' by virtue of the **Hedgerow Regulations 1997**.

2.11. Where development proposals abut woodland, normally only the woodland edge trees will need surveying. Where development is proposed within a woodland, all the trees will need to be surveyed.

2.12. Trees on some sites may form the basis of locally important wildlife habitats or enhance other adjoining valuable habitats. In such cases, qualified ecological advice should be obtained and where appropriate, an evaluation report added to the survey information.

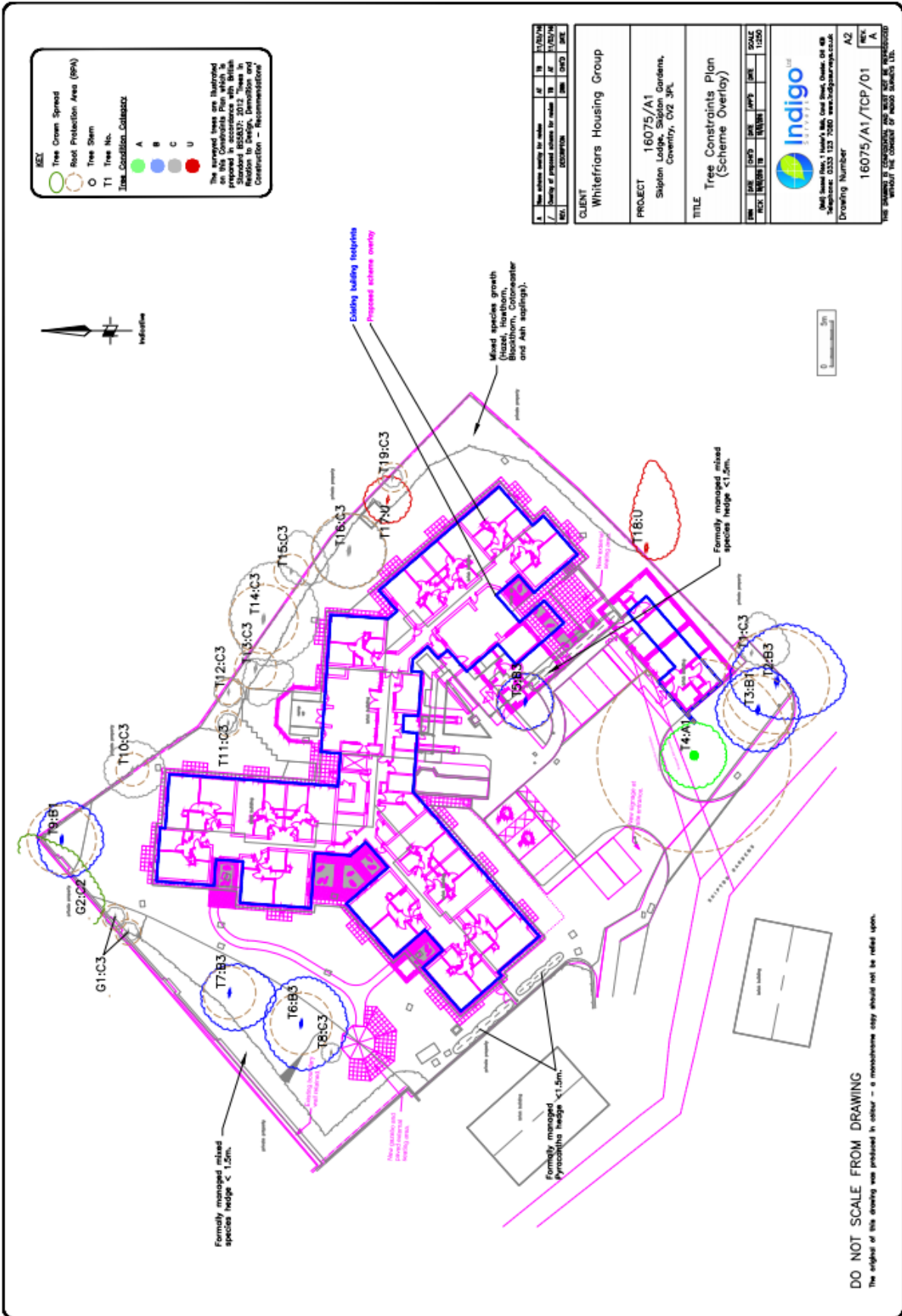

Best-practice example of a Tree Survey Schedule.
Reproduced with kind permission from Indigo Surveys Ltd.

TREE CONSTRAINTS PLAN

2.13. The **Tree Constraints Plan** (TCP) is an essential tool to help the design team plan the development, whilst retaining 'important' trees. It shows the 'above and below ground constraints' from existing trees that need to be considered. It must include:

- Below ground constraints; the **Root Protection Area** (RPA) around each tree or group of trees and hedges, which should be determined by reference to **Section 5** of **BS 5837:2012**. Please refer to paragraphs 4.13 to 4.20 for further details concerning RPA's.
- Above ground constraints; the current and ultimate height and spread of Category A, B and C trees, where this would cause unreasonable obstruction of sunlight/daylight to the development. The extent of shadowing should be shown on the plan. This can be calculated using proprietary software, but in practice, can be represented by a segment with a radius from the centre of the stem equal to the height of the tree drawn from due North West to due East to indicate the shadow pattern during the main part of the day.

2.14. The current and ultimate height and spread of a tree are also constraints due to size, dominance and movement in strong winds, and should be taken into consideration as a constraint at the design stage.

ARBORICULTURAL METHOD STATEMENTS

2.15. The submission and approval of a detailed **Arboricultural Method Statement** (AMS) will generally be required as part of a tree protection planning condition and will be expected to address the following:

- Timing and phasing of all arboricultural works in relation to the proposed development.
- Implementation, monitoring, supervision and maintenance of the TPS.
- Implementation, monitoring, supervision and maintenance of the tree work specification/schedule/scheme.
- Implementation, monitoring, and supervision of any approved development works or construction activities within the defined exclusion zone.
- Provision for regular monitoring of ongoing development operations to ensure full compliance with the approved TPS and AMS for the duration of the development.
- The setting up of an agreed framework for maintaining appropriate levels of communication between all involved parties.
- Provision for qualified arboricultural supervision.

2.16. Planning conditions and/or legal agreements will be attached to planning permissions to ensure full compliance with the approved AMS. Failure to comply with the terms of the approved AMS or any other conditions or legal agreement imposed upon a planning consent, or any other action which results in the loss of or damage to trees or hedgerows which have been specified for retention, may result in enforcement proceedings. Or where appropriate, prosecution under the relevant sections of the Town and Country Planning Act 1990; Town and Country Planning (Trees) Regulations 1999 (as amended),

Town and Country Planning (Trees in Conservation Areas) Regulations 1975 (as amended), Hedgerow Regulations 1997, and the Town and Country Planning (Tree Preservation) Regulations 2012.

CAPITAL ASSET VALUE FOR AMENITY TREES

- 2.17. **Capital Asset Value for Amenity Trees** (CAVAT) is a UK developed approach to express the amenity value of trees in terms of cost for equivalent replacement. This is the popular method within the arboricultural industry for managing trees as public assets. Furthermore, the functional value of the tree factors in the local population density to represent its role in the amelioration of a particular locality.
- 2.18. This approach is intended particularly for councils and other public authorities and primarily for publicly owned trees. However, it may be used by other public bodies, including the courts, private institutions and individuals to assess other components of an areas stock. This is because the Town and Country Planning Act 1990 (sections 198 & 199) establishes that trees have value as a public amenity and that local planning authorities have a duty to act to protect trees in the public interest. It is therefore of particular value to trees benefiting from a TPO or that meet the criteria for such an order.
- 2.19. The system is designed not only to be a strategic tool and aid to decision-making in relation to the tree stock as a whole, but can be applied to both individual and groups of trees; as well as healthy and damaged trees (directly and indirectly) or trees which are accused of damaging property.
- 2.20. In the case of damaged or destroyed trees, a compensatory value is calculated; in the case of damaging trees, trees are ranked to set the required levels of evidence as part of the Joint Mitigation Protocol. In all circumstances where the value of a single tree needs to be expressed in monetary terms, it is beneficial.
- 2.21. CAVAT sets out to assess the monetary value of a tree by calculating a unit value for each square centimetre of tree stem based on the average tree cost and using that figure to produce an average cost for each centimetre of trunk diameter. For the purposes of assessing the monetary value of the trees, they must be considered as individuals using the Full Method (detailed below). The Community Tree Index (CTI) factor for Coventry is calculated to be 125% for its population density, as sourced from Office of National Statistics⁸.
- 2.22. The Full Method (May 2018) involves seven steps, and sets of key variables:
- Basic value/unit value of tree size.
 - CTI value/location, in terms of population density.

⁸ <https://www.ltoa.org.uk/documents-1/capital-asset-value-for-amenity-trees-cavat/125-national-community-tree-index>

- Location Value, based on a tree's visibility from public vantage points, and the tree's public accessibility.
- Functional Crown Value/ structural factor value Part 1.
- Functional Crown Value/ structural factor value Part 2.
- Amenity value/positive and negative factors.
- Full value/life expectancy of tree.

2.23. The Full Method is used in situations when a more detailed and precise assessment of the value of trees as individuals is required.

2.24. The replacement value calculated enables realistic replacement and/or compensation to be achieved in relation to:

- Development Management functions;
- Management decisions, including for trees subject to TPO's, or in conservation areas;
- Assist in legal proceedings, (for example to advise a court as to the value of a tree, either publicly or privately owned, following the tree having been illegally removed or damaged, or in planning enquiries or appeals); and
- Management of the tree stock, to allow agreement as to adequate funding of replacement planting.

2.25. Given its links to public sector organisations and recognised weight in matters of planning, appeals and court proceedings, the CAVAT approach represents the Council's preferred method for calculating tree values when circumstances require it. However other approaches are available for use including the 'Helliwell System', 'CTLA approach' and 'i-Tree' etc. Should an applicant wish to rely on an alternative method, they should notify the Council at the earliest possible opportunity. However for clarification, the use of any approach will be a last resort as the Council's preferred position will always seek to ensure the retention of trees.

2.26. Further details of CAVAT can be found on the London Tree Officer's Association website: <https://www.ltoa.org.uk/>

DESIGN CRITERIA

2.27. The Council will take account of adopted local plan policies, relevant SPD's, and the most up-to-date legislation, Government advice and recommendations (as issued through refreshed PPG). The Council will not normally grant planning permission for:

- Developments which directly or indirectly threaten trees or woodlands of significant amenity value;
- Developments which have inadequate or inappropriate landscape proposals that fail to provide measures to conserve, or where appropriate, enhance the character of the landscape; or
- Developments which directly or indirectly threaten 'important' hedgerows.

2.28. The creation of a sustainable tree stock is a prime consideration when planning any landscape scheme. It is important that the tree stock incorporates trees of all age ranges and a diversity of species; appropriate to the particular location and landscape character.

2.29. In general, site layouts will be expected to:

- Provide for the retention of as much of the existing tree cover as is practicable. The allocation of space of trees must be assessed in terms of the overall landscape of the area; continuity and long-term sustainability of tree cover are important criteria to be considered.
- Make adequate provision for long-term retention of trees, groups of trees or areas of woodland, which are identified as having significant current or potential future amenity value as set out in **BS 5837:2012**. Preference should be given to retaining A and B category trees, however there will be instances where C category trees should be retained; for example until new planting is established (generally allow 10 years) or to provide temporary screening.
- Provide for the retention of as much of the existing hedgerow cover as practicable.
- Ensure the long-term retention of all 'Important Hedgerows' according to the **Hedgerow Regulations 1997**.
- Allow appropriate space for new planting.
- Ensure that where proposals include the felling of existing trees, landscape schemes make provision for sufficient replacement planting to compensate adequately for any resulting loss of amenity.
- Include sufficient information to allow for a full, detailed assessment of the short and long-term arboricultural and landscape implications of the development proposals to be made.

2.30. The layout of any development must be designed with detailed reference to the site survey information, particularly the Tree Survey and the **Arboricultural Impact Assessment (AIA)**.

2.31. Whilst the AIA should inform site layout design, it is recognised that with the competing needs of development, trees are only one factor requiring consideration. Therefore, it is essential to identify the most 'important' trees for retention and ensure that sufficient attention is given throughout the design and construction process to ensure that these can genuinely be retained in the long term.

2.32. The AIA should also identify the impact of the proposed design and layout on existing trees and detail measures to mitigate adverse effects.

APPLYING FOR PLANNING PERMISSION

- 2.33. It is essential that all relevant information pertaining to the assessment of trees and landscape issues on a site is submitted with the planning application.
- 2.34. Where a development is likely to affect existing trees on or adjacent to a site, the applicant will be expected to give due regard to the full range of construction-related activities that have potential to cause damage to trees. In these instances the applicant will be expected to forward all the relevant detail necessary for the Council to make an accurate assessment of the short and long-term arboricultural implications of the proposals.
- 2.35. Please refer to the Council's *Local Validation Requirements* for the details required prior to; validation of an application, determination of an application, or the discharge of the planning Condition relating to tree protection.
- 2.36. Permitted development which affects protected trees or hedgerows, may still require a formal application for consent under the Tree Preservation Order, Conservation Area or Hedgerow legislation. As part of the Council's pre-application service, the Council's officers are available to provide detailed, technical advice on such matters and it is advisable to discuss permitted development proposals with them prior to the commencement of any works.

2.37. Trees are material considerations in the formal planning system and developers should anticipate the need to accommodate trees within a development; whether through the retention of existing trees, tree planting directly, or through the provision of sufficient private space for future occupiers to carry out their own planting.

2.38. Trees impinge on many aspects of site development. It is therefore essential that due consideration should be given to the requirements of trees by all members of the development team throughout the design stages. Developers are encouraged to produce layouts or development site master-plans for discussion, prior to the submission of the details at the application stages. Such plans should be prepared with professionally qualified arboricultural and landscape design input.

IMPLEMENTATION

2.39. This section refers to any tree felling, transplanting or tree surgery works recommended as part of the **Tree Survey**, which may be necessary prior to, or during implementation of, an approved planning permission, or which may be required upon completion.

AVOIDING DAMAGE TO EXISTING TREES

2.40. Trees' roots are fragile; careful consideration must therefore be given to ensuring that trees and hedges, which have been identified for retention, are not directly or indirectly damaged by any proposed works. This can be done by paying attention to the Tree Survey and constraints information which enables **Construction Exclusion Zones (CEZ)** to be determined based on the RPA⁹.

2.41. The CEZ will be expected to remain undisturbed for the duration of the development. Site layouts should therefore be designed to avoid any construction works within the identified exclusion zones and should make adequate provision for sufficient working space and movement around the site.

2.42. Where development proposals include construction works within the identified exclusion zones, or where it is considered that a site cannot accommodate all of the operations associated with the implementation of a proposed development, without the need to intrude into the exclusion zones, the Council will request the submission of detailed construction specifications and method statements, in order to determine the likely effects of such works on the long-term health and structural stability of the trees. The Council expects full details of all such works to be submitted as supporting documentation to an application, and is unlikely to agree to conditional approval otherwise.

⁹ RPA's are calculated by multiplying the diameter of the tree in millimetres at 1.5 metres above the ground by 12 (**diameter (mm) at 1.5m height x 12**). RPA's should be calculated by the qualified arboricultural consultant. Development should be kept out of these areas or the drip-line of the tree – whichever is greater.

- 2.43. Where 'minimal dig' or 'no-dig' engineering treatments, using geotextiles and/or cellular confinement systems, are proposed for new areas of hardstanding within defined exclusion zones, the Council will usually require a detailed site and construction-specific method statement to be submitted as part of the planning application.
- 2.44. Where such proposals are deemed acceptable, the Council will expect provision to be made for qualified arboricultural supervision and monitoring of all works within the agreed exclusion zones.
- 2.45. The provision in Section 4.2 of **BS 5837:2012**, for off-setting the RPA by up to 20% in one direction, will only apply in certain specific circumstances, and should not be taken as a generalisation. There will be a presumption against such reductions, which will only be considered when accompanied by a detailed justification, based on accepted arboricultural principles.
- 2.46. Where proposed construction works are deemed likely to compromise the structural stability or long term health of trees and hedges, which are not subject to any legal controls and are situated outside the site, the applicant will be expected to liaise with the respective landowners. Removal of, or damage to such trees, may require the prior consent of the owner.
- 2.47. Foundation and/or superstructure designs should take account of **BS 8004:2015**– *Code of Practice for Foundation*, and **National House Building Council (NHBC) Standards, Chapter 4.2 (2018)**¹⁰ – *Building near Trees*.

DIRECT & INDIRECT DAMAGE

- 2.48. Direct damage is caused by the physical/mechanical damage to the crown, trunk and roots resulting from above ground physical contact, and trenching and excavation work within the RPA of a tree.
- 2.49. Indirect damage may be caused by soil compaction, toxicity or changes in temperature within the tree's RPA, usually resulting from the driving of heavy machinery especially during wet conditions, or the stockpiling of the heaps of heavy soils or building materials upon the RPA. This may result in significant damage to the tree's rooting environment.

¹⁰ The standards can be found using the following hyperlink:
<http://www.nhbc.co.uk/builders/productsandservices/standardsplus2018/#40>



Damaged soil structure from the passing site vehicles within the Root Protection

- 2.50. Soil compaction disrupts the plant's vital function of root respiration, as required by all living organisms. Tree roots respire by the vertical uninterrupted diffusion of gasses from the roots. The compaction can also kill off a trees' symbiotic relationships with mycorrhizae and other soil associates.

TREE WORKS

- 2.51. All tree work schedules and specifications should be detailed, precise and accurate; be drawn up in accordance with current arboricultural best practice and in-line with the requirements of **BS 3998:2010** – *Recommendations for Tree Work*. They should include sufficient levels of detail for an accurate assessment of the full implications of the proposals to be made.
- 2.52. Tree Work Schedules must be approved by the Council, prior to implementation. In some cases, an additional **Tree/Woodland Management Plan** and related **Method Statement** may be required to be submitted for approval.
- 2.53. The Council expects all tree work operations to be carried out to the highest standards as set out in British Standards, and will apply planning conditions and use TPO's, where necessary, in order to ensure that such standards are upheld.
- 2.54. It is the responsibility of the developer appointed qualified arboriculturalist to ensure all retained trees are monitored throughout the construction period, and

any changes to tree protection measures are agreed in writing by the LPA Tree Officer.

2.55. The Council recommends the use of qualified arboriculturists, with appropriate levels of expertise, qualifications and insurance cover. The Arboricultural Association is an organisation that maintains an approved list¹¹.



TREE PROTECTION MEASURES

2.56. Trees on development sites are particularly vulnerable to disruption during the construction process, and damage is often irreparable leading to decline and premature death. Tree root systems are especially sensitive to construction damage. Such damage is not usually deliberate, but more often than not, due to a lack of understanding of how easily trees can be harmed by nearby activities.

2.57. **BS 5837:2012** provides clear guidance on the implementation of a **Tree Protection Plan (TPP)**, and the Council expects the contents of this document to be complied with.

¹¹ Copies of Directories are available from the Arboricultural Association. This can be found using the following hyperlink: <https://www.trees.org.uk/Registered-Consultant-Directory>

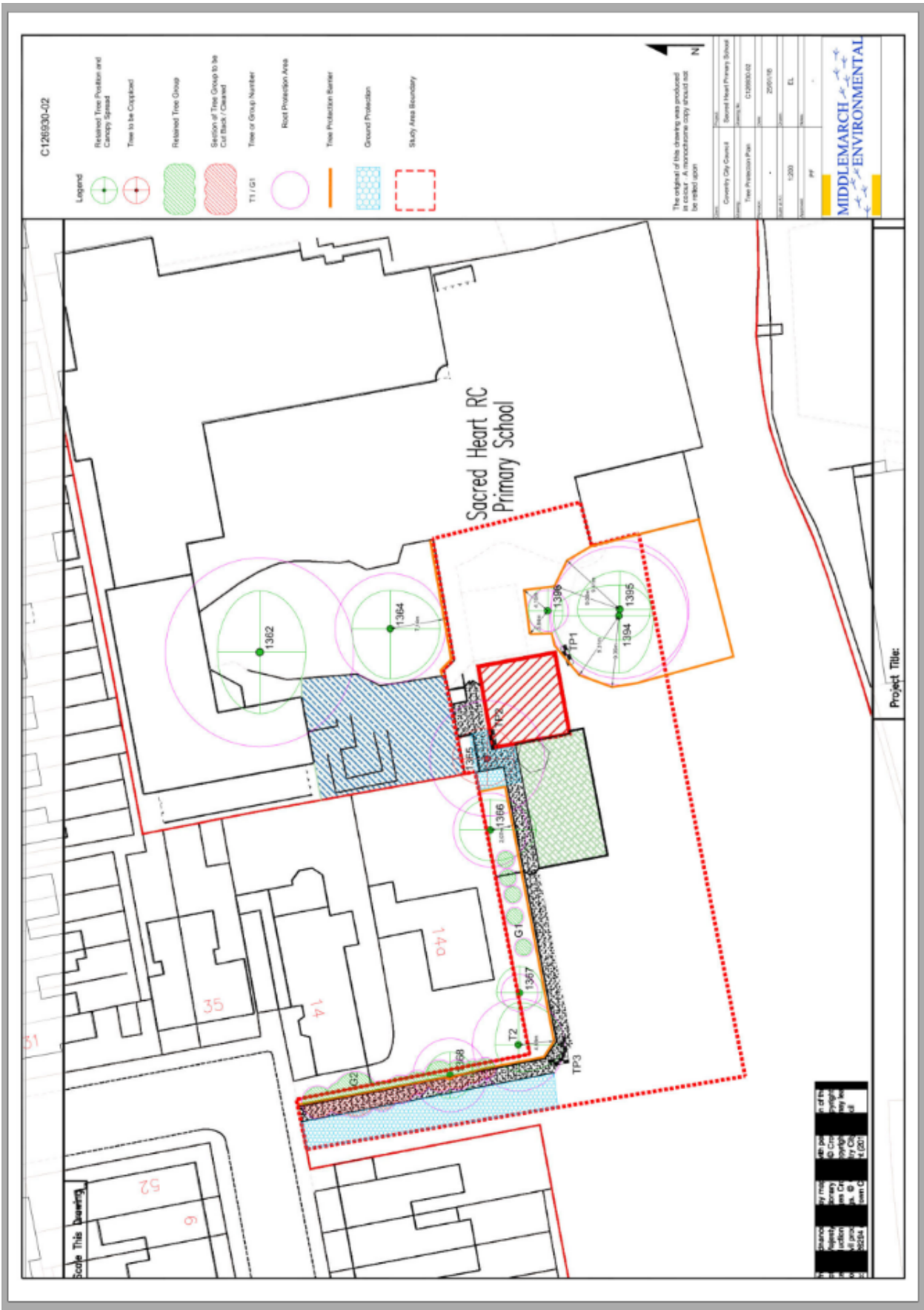

Best-practice example of a Tree Protection Plan.
 Reproduced with kind permission from Middlemarch Environmental Ltd.

- The positioning of protective barrier must ensure that the development can be implemented without intruding into the exclusion zones.

ROOT PROTECTION

- 2.60. As the morphology of the tree crown establishes from sapling stage to maturity it develops a more spreading crown. In ratio to this its root system modifies from its initial deep rooting taproot, to that of a more efficient spreading system of rapidly subdivided lateral woody roots comprised of dropper and sinker roots, which extend well beyond the drip line edge of the crown's outermost branch tips. These systems display a rapidly subdividing fibrous non-woody root structure.
- 2.61. Most of the roots of a mature tree are within the upper 600mm of the soil surface where the higher levels of moisture, oxygen and nutrients are found, for healthy growth and survival.
- 2.62. The health of a tree's root system is vital to its long term well-being, and any activity which affects the soil structure, may also damage or kill the fine roots or alter the balance of moisture, oxygen and nutrients within the rooting zone. This can affect the whole tree.
- 2.63. The root system is equally important in terms of structural stability. The mass of soil particles bound together by the fibrous roots create a structural counter-balance to the above ground parts of a tree. Structural stability may also be impaired by excavation within the rooting zone, even where major roots have not been severed.



Damage or severance of main structural roots, as well as killing off the distal portions of the fine root system, may also affect a trees stability rendering it dangerous by increasing its chances of structural failure.

2.64. Potentially damaging operations include:

- Excavation within the rooting zone.
- Raising or lowering of ground levels.
- Compaction of the soil by construction works, site machinery or vehicles, and the storage of materials and debris.
- Storage of building materials.
- The dumping or spillage of toxic or caustic material such as diesel, solvent and cement.
- The installation of impermeable surfacing.
- Direct damage to trunks and branches by construction vehicles.
- Fires built closer than 20 meters from the outer crown.

2.65. The Council will normally require detailed **Tree Protection Measures** (TPM) to be submitted for approval if any of the above are proposed. It will be expected to make provision(s) for the retention and protection of trees, shrubs and hedges growing on or adjacent to the site. This will also include locations for new tree planting.

2.66. Ground protection may be required during development to avoid compaction. Where it has been agreed during the design stage and shown on the approved Tree Protection Plan (TPP) that certain operations may take place within the

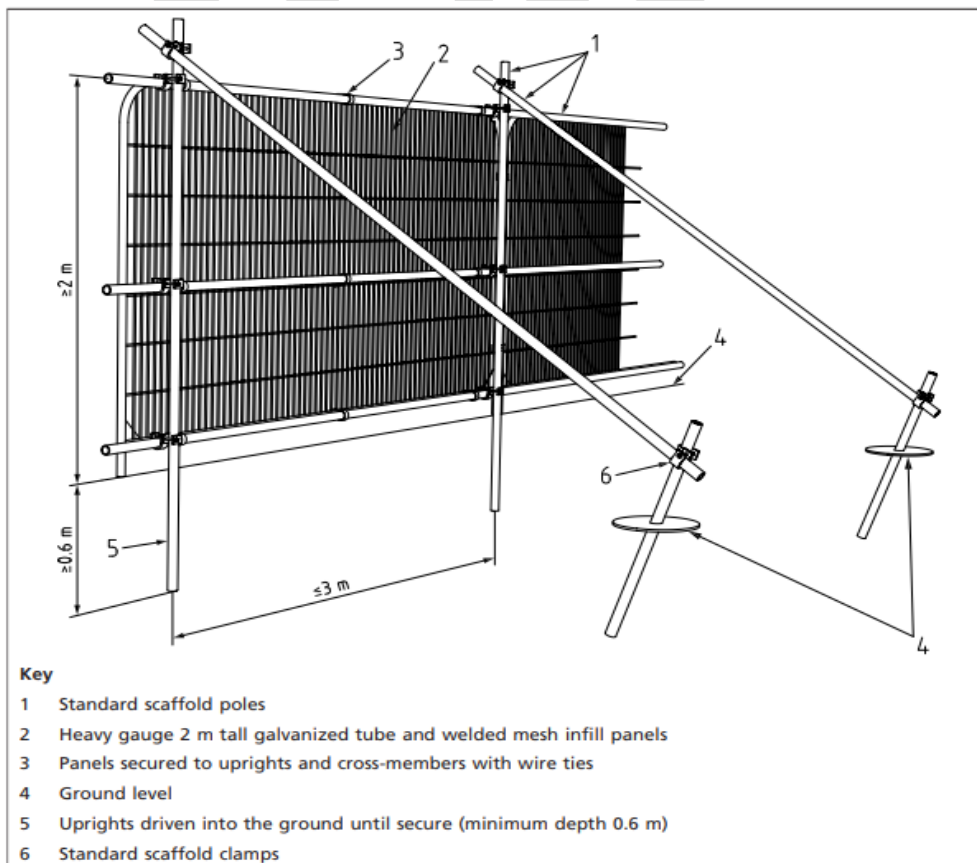

Figure 2 - Default specification for protective barrier.

Reproduced with kind permission from the British Standards Institute.

RPA, ground protection will be necessary in addition to protective barriers. Refer to **Figure 2** of **BS 5837:2012** for scaffolding within the RPA.

2.67. Where trees are of TPO quality, the LPA may require site monitoring by a qualified arboriculturist. The AMS would illustrate a Site Monitoring Sheet (SMS) where key phases of construction are monitored and signed off by a qualified arboriculturist. This is to ensure that the tree protection pens and any ground protection have been correctly erected prior to any site activity taking place and where they must remain in place until the end of the physical build phase. The final phase would be to confirm the end of the physical construction phase, when the tree protection pens may then be dismantled.

AVOIDING OTHER DAMAGE

4.32 The long-term implications of any construction work within the exclusion zone(s) should also be carefully assessed in relation to **Table 3** of **BS 5837:2012**. New structures, drains, services, walls, paths, driveways and areas of hardstanding should be sited or designed so as to avoid direct damage from future growth of the bole and main structural roots of retained trees¹².

¹² For guidance on avoiding indirect damage by trees to structures, please see the NHBC Standards: Chapter 4.2(.3) using the following hyperlink:
<http://www.nhbc.co.uk/Builders/ProductsandServices/Standardsplus2018/#1>

Common causes of Tree Death

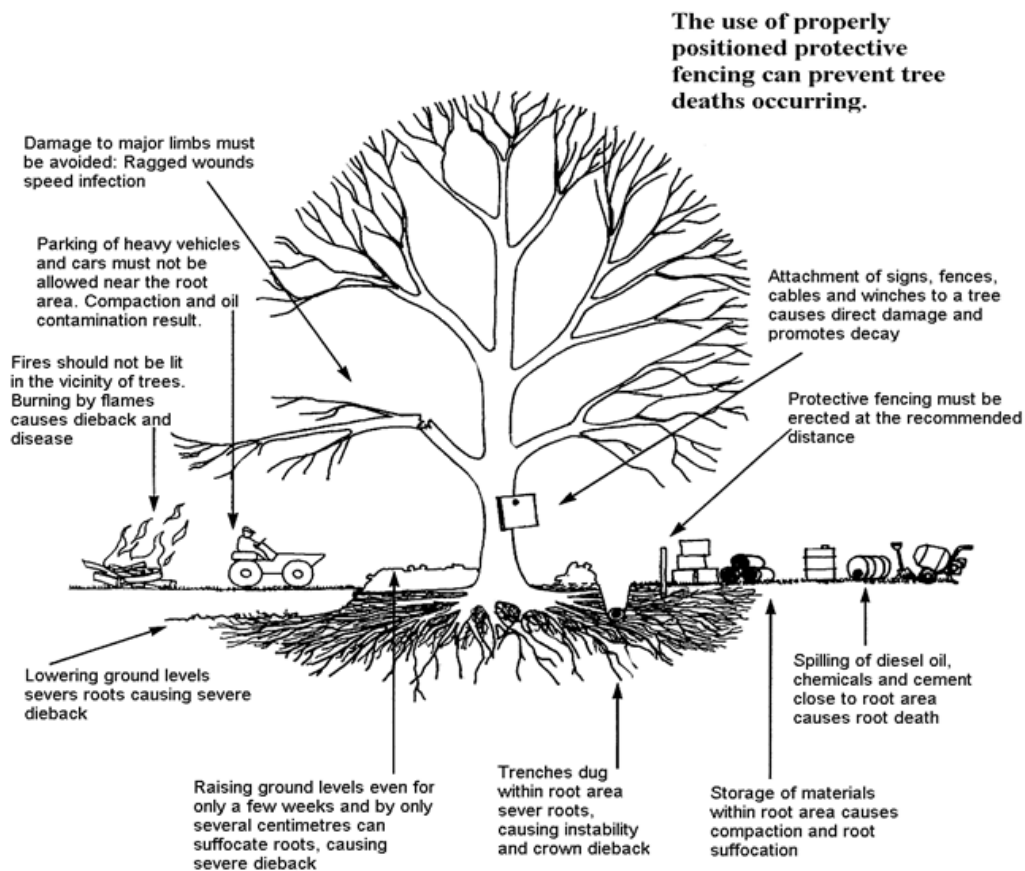

PRINCIPLES OF TREE PLANTING

- 4.33 Quality tree planting schemes on development sites can contribute to the creation of a high level of amenity and an attractive environment, whilst maintaining a relation to the character of a site and its surroundings.
- 4.34 Tree planting should be recognised from the outset as an integral part of any development scheme landscape plan, and should be purposefully designed to complement the proposed features of the development and those existing features intended for retention. On sites that have no existing trees, it is especially important to plan for the planting of trees as part of the development.
- 4.35 Tree planting will be expected to contribute, on an effective scale, to the conservation or enhancement of the landscape, providing an overall environmental benefit in terms of public amenity and nature conservation.
- 4.36 Planting schemes should be appropriate for the intended use of the development, and will be expected to contribute to the establishment of a well-structured framework of diverse ages, sizes and species with the potential to be managed constructively over decades or even centuries. It is very important to incorporate some large-stature, long-term trees whenever possible, but it is essential that sufficient space is allowed in the layout for their ultimate size.

4.37 Developers should recognise the functional role of tree planting in enhancing the physical characteristics of a development: providing shelter, screening, enclosure, 'softening' the outline of buildings, defining space, directing routes and views, or simply to enhance the visual amenity of an area. Particular attention should be given to the use of tree planting to enhance public areas within developments, and views into the site from surrounding public spaces.

4.38 In locations where nature conservation objectives are particularly important, planting schemes will be expected to maximise the benefits to wildlife, through the use of a range of native trees and shrubs suited to the ecology of the locality. Due consideration should be given to layout configuration, planting density, choice of species, species mixes, proportions and edge characteristics. Such schemes should always be prepared with input from professionally qualified ecological advisors including the authorities own Ecology Officer.

4.39 The overall principles should include;

- Principles of Planting Design, where percentages of appropriate tree, shrub and herbaceous species are considered from Ancient Arden, wider native species including species to encourage wildlife and ecology, and decorative species,
- Plants as Elements of Landscape, to include prospective planting, planting as focal points, to create barriers for screening, windbreaks and mark boundaries etc,
- Plant characteristics to consider tree and crown form, foliage, seed and fruit types, light, shade and shadows upon landscape, colour, texture, contrasts and harmonies of seasonal variation, age class generation planting, deciduous to evergreen etc.
- Planting Layout, to consider appropriate species of a tree's ultimate height, crown spread and root morphology, for open spaces, site entrances, junctions, marginal planting for internal roads dependent upon space availability from the more special boulevard planting to a site's more restricted narrow road layouts where narrow fastigiate species may be selected.

4.40 Additional information on tree planting design will be available within the Council's other SPD's: *Urban Extension Design Guide* and *Residential Design Guide*.

AVOIDING FUTURE CONFLICT

4.41 As set out in paragraph 31 of PPG, trees, as a component of green infrastructure, must provide benefits in the long-term. This should be factored into the way that proposals are designed and implemented.

- 4.42 Development layouts, even if not affecting trees directly, may not be acceptable if they would result in undue pressures, in the short or long term, for felling or excessive pruning of important trees by future home-owners and commercial landlords.
- 4.43 Site layouts which merely avoid the exclusion zones may not necessarily be adequate. Other factors must be taken into account to ensure that trees, which are to remain, can reasonably be retained to maturity, thereby providing maximum amenity benefits with minimum maintenance requirements.
- 4.44 In considering the juxtaposition of trees and buildings, site layout designs will be expected to ensure that trees which are to remain are given adequate space, including sufficient allowance for future growth, without the need for excessive or unreasonable pruning.
- 4.45 Site layouts should ensure that private garden areas are of adequate size, are large enough to enable normal domestic use and can reasonably accommodate the trees, including allowance for future growth. Private garden areas should normally be sufficient to allow reasonable extension of the main dwelling and other permitted development rights without reducing the amount of usable garden space to unacceptable levels.
- 4.46 The predicted mature height, branch spread, and crown form of individual trees should be assessed in conjunction with site factors such as aspect, topography, soil conditions and exposure. (The ultimate mature size of any individual tree will be dependent on site specifics, and an assessment from a qualified arboricultural consultant should be sought).

PLANTING NEW TREES

- 4.47 Tree planting should aim to make the optimum long-term use of allocated space without causing unreasonable future inconvenience to occupiers.
- 4.48 In order to ensure that new trees do not interfere to such an extent that unsightly, heavy pruning or removal becomes necessary, the following factors will require attention:
- There should be careful choice of species and siting to ensure maximum long-term amenity benefits and minimising potential future conflict.
 - Decisions regarding species and siting should be taken based on an assessment of the potential dimensions and growth habit and maturity; which will give an indication of whether future pruning requirements are likely to be acceptable.
 - Careful siting of new trees with reference to **Table A.1** of **BS 5837:2012** will ensure that future root damage to structures, drains, services, walls, paths and drives is prevented, or at the very least minimised.
 - The inclusion of professional arboricultural input into the landscape design stages is highly recommended, whenever new tree planting is proposed.

- 4.49 Planning conditions will normally be used to ensure that planting schemes are planned, implemented and maintained to provide maximum long-term benefits. Therefore the submission of a fully informed planting scheme, in support of a planning application, will usually be required for development sites.
- 4.50 The Council expects sufficient information to be provided to judge the value of planting schemes. Consideration should be given to augmenting proposals with cross-sections, projections and illustrative drawings.
- 4.51 The minimum level of detail required for new tree planting proposals are:
- An accurate, detailed planting plan and schedule.
 - A comprehensive list of species and stock specification.
 - Details of planting densities and spacing.
 - Individual locations of specimen trees and shrubs.
 - Clear indication of existing trees specified for retention and those for removal.
- 4.52 The long-term aims of a scheme can only be achieved if the new planting succeeds. The Council will pay particular attention to practical measures that are proposed as part of any scheme, to ensure successful establishment. Planting schemes are expected to include the following provisions:
- Preparation of the planting environment (including decompaction and drainage) should be at least to the standards set out in the **BS 4428:1989 – Code of Practice for General Landscape Operations (excluding hard surfaces)**.
 - All plant material provided will be expected to comply with, and be planted, in accordance with the requirements of; **The Horticultural Trades Association National Plant Specification, BS 8545:2014 – Trees: from nursery to independence in the landscape – Recommendations**, as appropriate.
 - Final planting positions for new trees will be expected to take account of the requirements of **BS 5837:2012**.
 - The inclusion of a management plan and detailed maintenance schedule in accordance with the requirements of **BS 4428:1989**.

SITE LAYOUT

- 4.53 Site layouts must also ensure that trees at maturity will not dominate buildings, which would lead inevitably to concerns about safety and ultimately to requests to fell or heavily prune. Where large, mature, aged or veteran trees or Ancient Woodland are located on or adjacent to the site, an adequate buffer and space must be allowed for their development and long-term physical protection and maintenance by incorporating into open space.

4.54 Furthermore, site layouts must ensure that trees will not cause unreasonable obstruction of direct sunlight or daylight to properties¹³. Reference should be made to the information provided on the AIA. Factors requiring detailed deliberation include; individual species characteristics (e.g. potential for future growth), and garden size and layout (e.g. the aspect of the tree from the building, building to tree clearances, building orientation, and the positioning and size of windows - especially in habitable rooms).

Moat House as depicted on the 1st Edition Ordnance Survey map of 1888

Compiled by A Wilson on 21 July 2009

Coventry City Council
Scale 1:2500

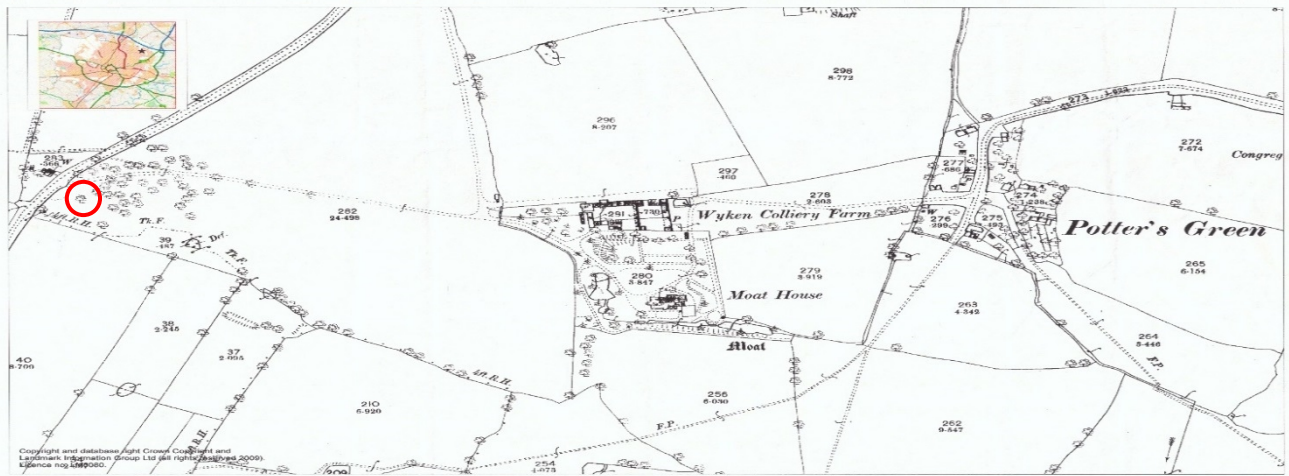

4.55 In addition, site layouts must ensure that due consideration is given to the pruning requirements of retained trees (full details should be included in the tree survey). Where pruning regimes, present or future, are recommended as a way of reducing the adverse effects of trees on a development, the Council will carefully assess whether such proposals are consistent with prudent arboricultural management, are likely to meet the suggested long term objectives and whether they are reasonable, enforceable and can practically be implemented. All tree works will be expected to comply with current arboricultural best practice, and meet the requirements of **BS 3998:2010**.

SITE ACCESS

4.56 The provision of permanent and temporary site access is an important part of the layout design stages and full details will normally be required in support of any planning application.

4.57 For safety reasons, site access layouts and visibility splay clearances may require the removal or pruning of trees and hedges. Where this is likely, applicants are encouraged to liaise with the Council through the pre-application process (as appropriate) to seek clear guidance of their requirements, prior to submission of an application. Although generally, permanent and temporary site access designs will be expected to avoid tree and hedgerow removals, and ensure the long-term retention of all important trees and hedges.

4.58 The need to make provision for site access on a temporary basis must also be given due consideration. Sites may require temporary access for long, wide, or high loads, and provision may be required for unusually large vehicles or machinery. The need to provide adequate operational space within the site, for specialised equipment, machinery and/or vehicles (including cranes and piling rigs), must also be considered. Any resulting short and long-term implications for trees and hedges which are to remain must be carefully assessed and full details submitted as part of any planning application.

4.59 Drainage and service layouts must be designed in such a way as to allow for installation and future maintenance without adversely affecting trees and their root systems. The provision of common service trenches may help to minimise potential conflicts.

4.60 Full details of service layouts should be submitted with any planning application. Service layout planning and installation should be carried out in accordance with methodology requirements set out within BS 5837:2012.

MONITORING & REVIEW

- 5.1 The provisions of this SPD will be implemented through the development management process, principally the determination of planning applications which involve trees.
- 5.2 Whilst this document does not have the status of the Local Plan (for the purposes of Section 38 of the Planning and Compulsory Purchase Act 2004), it will be a key material consideration in determining planning applications.
- 5.3 The effectiveness of this SPD will be assessed periodically through the planning departments review mechanism, namely the Local Development Scheme. The Council's Tree Officer(s) will continue to monitor the impacts that this document is having on the planning process and ultimately upon trees within development. It will also help to establish whether the intended effects, as set out in the aims and objectives, are being met.

DRAFT

“If a tree is treated as a living organism, with an understanding of its vital functions, it will be a constant source of profit and pleasure.”

Professor N.T. Mirov, University of California

DRAFT